

SINCE 1889



**Instruction Manual  
For  
GRAVITY CONVECTION OVENS**

**Model**

**DX300**

**DX400**

**DX600**

Ver.2

**Yamato Scientific America, Inc.**

**Santa Clara, CA**

**(800)292-6286**

# Contents

---

◆ <b>Safety Information</b> .....	<b>1</b>
• Safety Symbols.....	2
◆ <b>Installation</b> .....	<b>4</b>
◆ <b>Identification of Parts</b> .....	<b>9</b>
• Main Unit .....	9
• Control Panel.....	10
• Controller Characters.....	11
◆ <b>Operational Procedures</b> .....	<b>12</b>
• Operation Mode and Function List .....	12
• Operational Characters.....	14
• Overheat Prevention Device .....	15
• Fixed Temperature.....	16
• Quick Auto Stop.....	17
• Auto Stop.....	18
• Auto Start.....	20
• Other Functions.....	22
◆ <b>Handling Precautions</b> .....	<b>23</b>
◆ <b>Maintenance</b> .....	<b>25</b>
◆ <b>Troubleshooting</b> ... ..	<b>34</b>
◆ <b>Service and Warranty</b> .....	<b>29</b>
◆ <b>Specifications</b> .....	<b>30</b>
◆ <b>Wiring Diagram</b> .....	<b>31</b>
◆ <b>Replacement Parts List</b> .....	<b>32</b>
◆ <b>Reference</b> .....	<b>33</b>
• List of Dangerous Substances .....	33

## General Safety Information

### MEANING OF ILLUSTRATED SYMBOLS

#### Illustrated Symbols

Various symbols are used in this safety manual in order to use the unit without danger of injury and damage of the unit. A list of problems caused by ignoring the warnings and improper handling is divided as shown below. Be sure that you understand the warnings and cautions in this manual before operating the unit.

---

---

 **WARNING!** If the warning is ignored, there is the danger of a problem that may cause a serious accident or even fatality.

 **CAUTION!** If the caution is ignored, there is the danger of a problem that may cause injury/damage to property or the unit itself.

---

---

#### Meaning of Symbols



This symbol indicates items that urge the warning (including the caution). A detailed warning message is shown adjacent to the symbol.



This symbol indicates items that are strictly prohibited. A detailed message is shown adjacent to the symbol with specific actions not to perform.



This symbol indicates items that should be always performed. A detailed message with instructions is shown adjacent to the symbol.

## Safety Symbols

### Warning



Warning,  
general



Warning,  
high voltage



Warning,  
high temperature



Warning,  
drive train



Warning,  
explosive

### Caution



Caution,  
general



Caution,  
electrical shock



Caution,  
scald



Caution,  
no road heating



Caution,  
no drenching



Caution,  
water only



Caution,  
poisonous

### Forbidden



Forbidden,  
general



Forbidden,  
inflammable



Forbidden,  
to disassemble



Forbidden,  
to touch

### Requirements



Requirement,  
general



Requirement,  
connect to  
grounding  
terminal



Requirement,  
install on flat  
surface

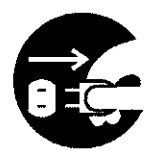

Requirement,  
disconnect power  
plug



Requirement,  
inspection

## Safety Precautions

### **WARNING!**

#### **Do not use this unit in areas where flammable or explosive gases are present**

Never use this unit in an area where flammable or explosive gases are present. This unit is not explosion-proof. An arc may be generated when the power switch is turned on or off, and can result in a fire and/or explosion. (Refer to page 33 "List of Dangerous Substances".)

#### **Always ground this unit**

Always ground this unit to avoid electrical shock due to a power surge.

#### **If problems occur**

If smoke or strange odors should come out of unit, turn off the power, circuit breaker, and main power off respectively. Contact your service technician for inspection immediately. Not following these procedures can result in fire or electrical shock. Performing repair work yourself is dangerous and strongly discouraged.

#### **Do not bundle the power cord**

Do not operate this unit if the power cord is bundled or tangled. Using it in this manner can cause the unit to overheat and result in fire.

#### **Do not process, bend, or stretch the power cord**

Do not process, bend, or stretch the power cord. Fire or electrical shock may result.

#### **Prohibited substances**

Never use explosive or flammable substances and/or substances that include explosive or flammable components. Not following these procedures may result in explosion or fire. (Refer to page 33 "List of Dangerous Substances".)

#### **Do not disassemble or modify this unit**

Do not disassemble/modify unit. Not following these procedures may result in fire or electrical shock.

#### **Hot surface**

The interior chamber and door may become hot during or just after operation. Contact with these surfaces may cause burns.

### **CAUTION!**

#### **During a thunder storm**

In the event of a thunderstorm, immediately turn off the power key, circuit breaker, and main power. Not following these instructions can result in fire or electrical shock may be caused.

## Installation Requirements

### **WARNING!**

#### 1. Always ground unit



*Unit is equipped with 115V Plug.*



- Be sure to connect the ground wire (green cable) to the grounding conductor or ground terminal to prevent accidents caused by electric leakage.
- Do not connect the ground wire to gas or water pipes.
- Do not use a branching receptacle.

#### 2. Choose a proper place for installation



- Do not install this unit in the following environments:

- ◆ Rough or dirty surfaces
- ◆ Areas where flammable or corrosive gas are generated
- ◆ Areas where ambient temperature exceed 35°C
- ◆ Areas where ambient temperature fluctuate
- ◆ Under direct sunlight.
- ◆ Areas with excessive humidity and/or dust
- ◆ Areas with constant vibrations



- Install this unit with sufficient space surrounding the unit as shown below. The exhaust opening is provided on top of the unit. Keep your distance from this port during or after operation.

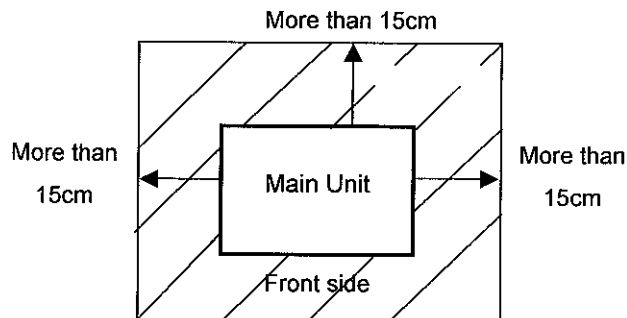

## Installation Requirements

### 3. Do not use this unit in areas where flammable or explosive gases are present (Refer to page 33 "List of Dangerous Substances".)



- Never use this unit in areas where flammable or explosive gases are present. This unit is NOT explosion proof. An arc may be generated when the power switch is turned ON or OFF, and may result in fire/explosion.

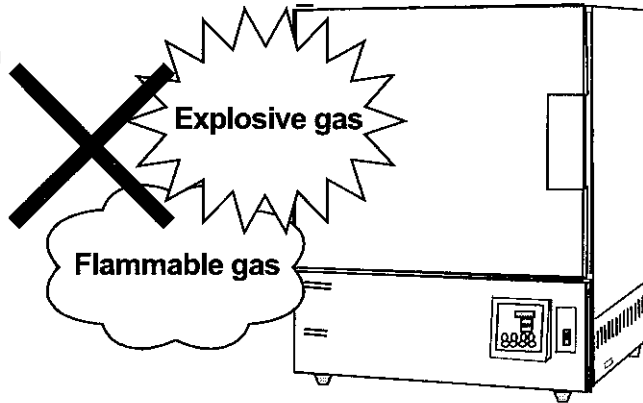

- Never use explosive or flammable substances or substances that include explosive or flammable components in this unit. This could result in explosion or fire.

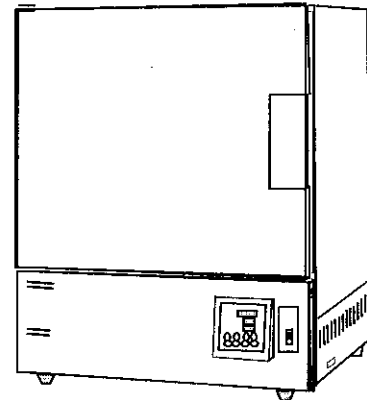

## Installation Requirements

### 4. Do not modify



- Modifications to this unit are strictly prohibited.

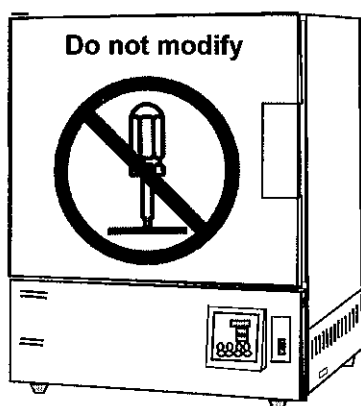

### 5. Install on flat surface



- Install this unit on a flat or level surface.

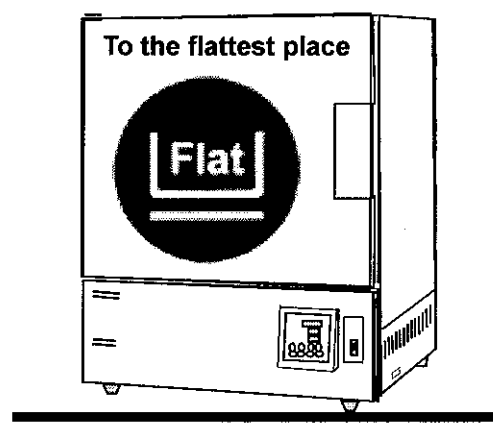

## CAUTION!

### 6. Do not overload



- The maximum capacity per shelf is 15kg (uniform load).

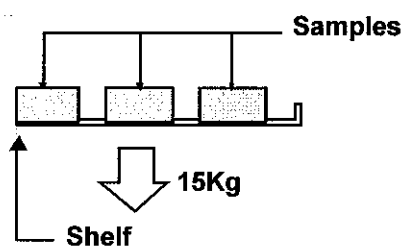

### 7. Set spacing between samples



- The temperature in unit cannot be controlled properly if your samples are overloaded. Allow 30% free space or more to acquire accurate temperature.

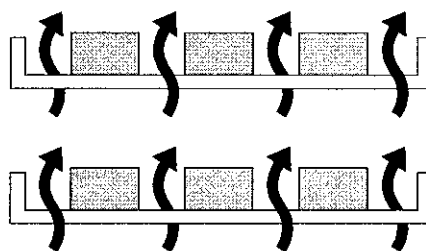

Provide samples with 30% space



## Installation Requirements

### 8. Choose the correct power distribution board or receptacle



- Choose a correct power distribution board or receptacle to meet the unit's rated electric capacity as follows:

<b>Electric capacity:</b>	DX300:	115V AC, 8A
	DX400:	115V AC, 13.5A
	DX600:	115V AC, 13.5A

**NOTE)**

In the event that this unit does not run after turning the power ON, follow the following steps. Inspect whether the voltage of the main power is lower than the specified value, or whether other device(s) are using the same power line as this unit.

### 9. Before/after installation



- Injuries can occur if this unit falls or moves due to earthquake, impact, etc. Take appropriate measures to prevent this from occurring.
- Contact with this unit may cause burns during and just after operation. Take appropriate measures to prevent this from occurring.

### 10. Handling



- Two shelves are installed with each unit. The lower shelf is factory installed with the shelf brackets screwed in.



- The factory installed bottom shelf is fixed/installed at the lowest level. The temperature of this shelf, due to location of heater is usually higher than the set temperature.

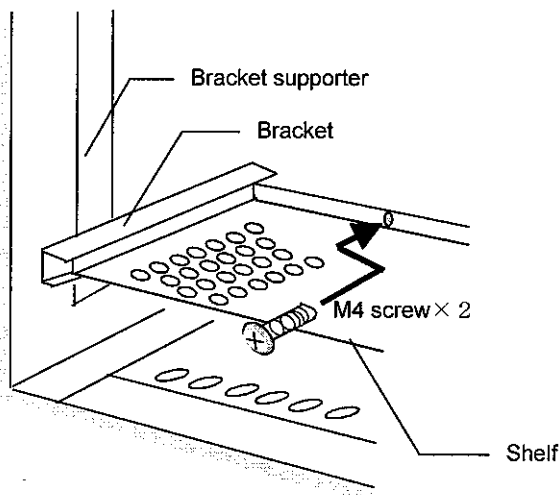

Never use explosive or flammable substances or substances that include explosive or flammable ingredients

## Installation Requirements

### 11. Handling the power cord

- ⊘ Do not bundle the power cord.
- ⊘ Do not bend or twist the power cord.
- ⊘ Do not place any objects small or large on top of the power cord.
- ⊘ Keep the power cord away from any heating equipment such as a room heater.
- ! If you damage the power cord, immediately turn the power and main power supply off.
- ! Connect the power plug to a receptacle with appropriate power and voltage.

### 12. Open exhaust opening

- ! This unit is equipped with two standard exhaust ports. Install the enclosed exhaust port covers in the port.  
Open the two exhaust ports (at least one-third opening recommended).  
Adjust degree of opening according to water content of sample.

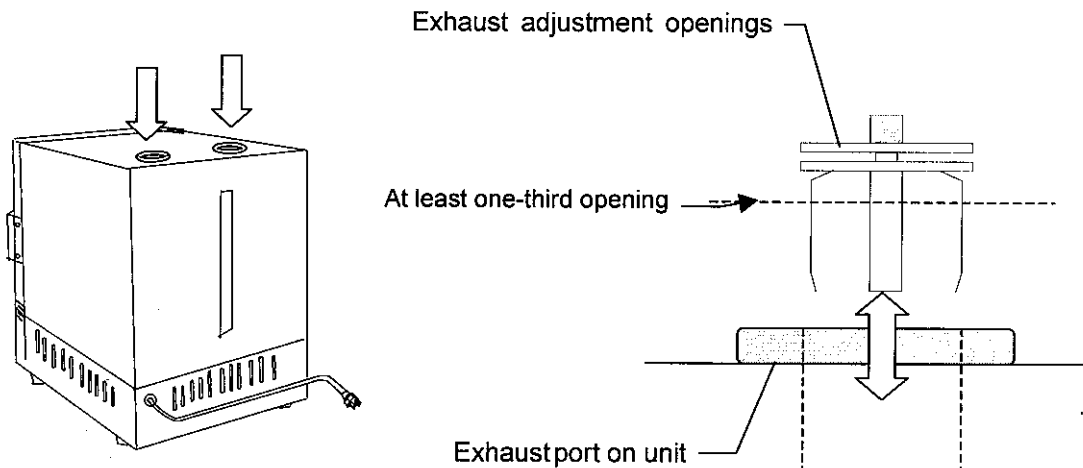

## Main Unit

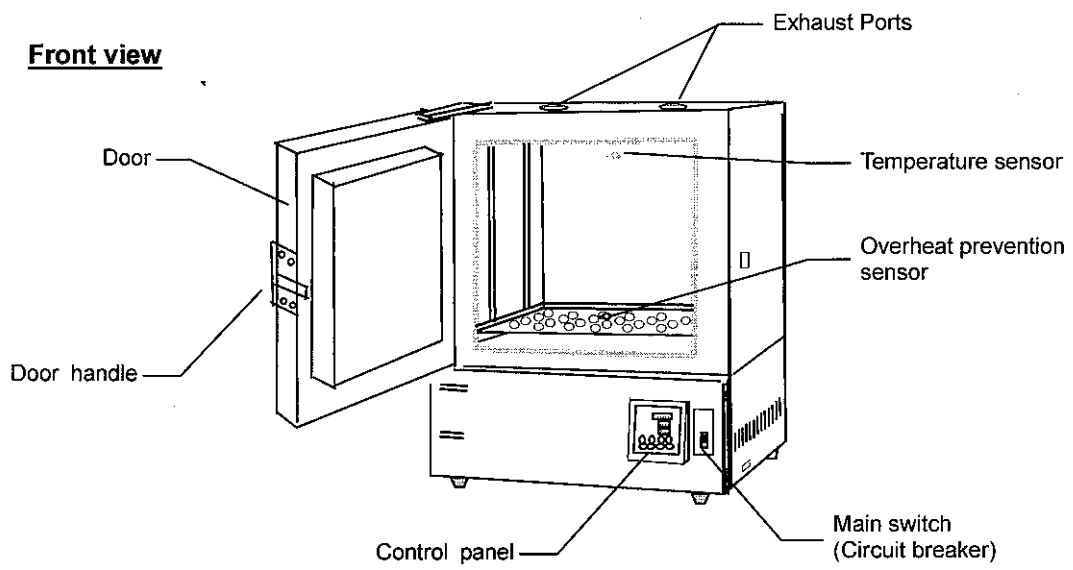

**Rear view**

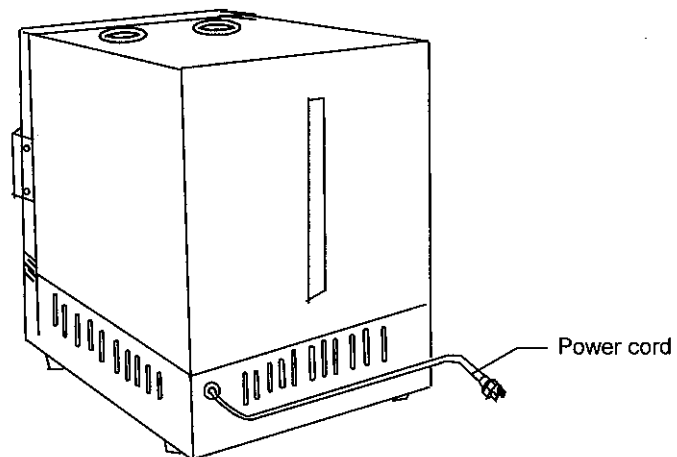

## Control Panel

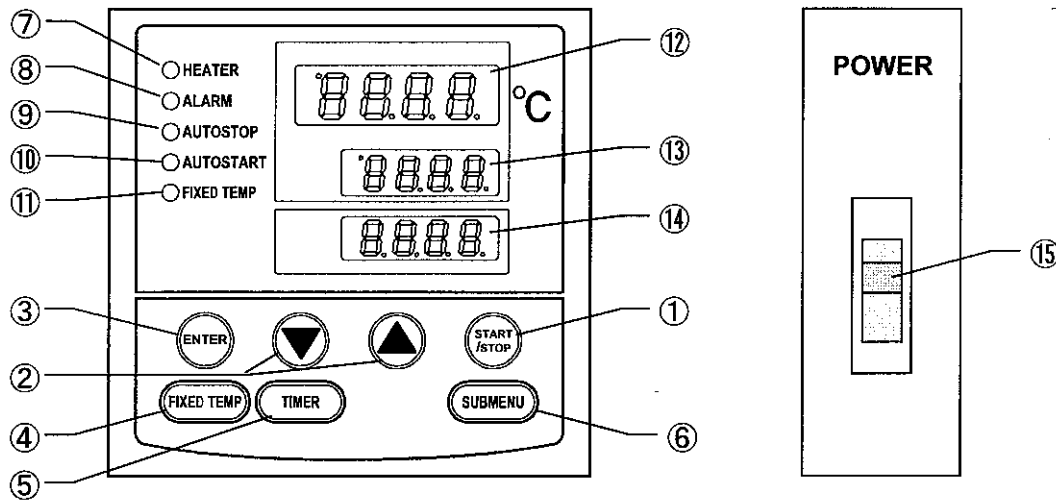

①	START/STOP Key :	Start / stop operation.
②	▲▼ Keys :	Used for raising or lowering the set values.
③	ENTER Key :	Enters each inputted value.
④	FIXED TEMP Key :	Selects the fixed temperature operation.
⑤	TIMER Key :	Selects the timer operation (Quick Auto Stop/Auto Stop/Auto Start).
⑦	SUBMENU Key :	Used for setting the overheat prevention, calibration offset temperature, key lock function, or program repeat function.
⑧	HEATER Lamp :	Lights up while heater operates.
⑨	ALARM Lamp :	Lights up if error is to occur. (Buzzer sounds simultaneously.)
⑩	AUTO STOP Lamp :	Blinks while setting quick or auto stop timer. Lights while quick or auto stop timer is running.
⑪	AUTO START Lamp :	Blinks while setting auto start timer. Lights while auto start timer is running.
⑫	FIXED TEMP Lamp :	Blinks while setting fixed temperature. Lights while fixed temperature is running.
⑫	Measured Temperature Display :	Displays the measured temperature, setting character, alarm information.
⑬	Set Temperature Display :	Displays the set temperature and value for timer mode, remaining time.
⑭	Overheat Prevention Temperature Display :	Displays the set temperature for overheat prevention device.
⑮	Power Switch : (Circuit breaker)	Turns ON/OFF the main power.

## Description and Function of Each Part

### Controller Characters

VS3 controller:

Character	Identifier	Name	Purpose
F, 11	FiX	Fixed Temperature Setting Mode	Used for starting fixed temperature operation.
50	Sv	Temperature Setting	Used for set temperature.
ASLP	AStP	Timer Setting Mode Display	Represents setting of quick or auto stop operation.
ASLr	AStr	Timer Setting Mode Display	Represents the setting of auto start operation.
t, n	tim	Time Setting	Used for set time.
End	End	Time Up	Displays when the timer operation is completed or while inputting the number of program steps.
cAL	cAL	Calibration Offset Setting	Used for setting overheat prevention device temperature. (Refer to Page 22 "Operational Procedure Other Function".)
oH	oH	Overheat Prevention Setting	Used for setting overheat prevention device temperature. (Refer to Page 15 "Setting of Overheating Prevention Device".)
LoCh	Lock	Key Lock	Locks the keys on control panel to protect from unintentional operation. (Refer to Page 22 "Operational Procedure Other Function".)

\* Also refer to Page 14 "Operational Characters".

## Operation Mode and Function List

The operation function of this unit is as follows:

No.	Name	Description	Page
1.	Fixed Temperature	Pressing the FIXED TEMP key enters the fixed temperature setting mode. Pressing it again enters the temperature setting mode. Pressing the START/STOP key starts or stops operation.	16
2.	Quick Auto Stop	This operation is used to specify the automatic stop mode. Press the TIMER key during fixed temperature operation. Pressing the START key starts the quick auto stop operation, activates the timer function and stops the operation automatically after the specified period.	17
3.	Auto Stop	This operation is used to specify the automatic stop time in the fixed temperature operation. Pressing the TIMER key displays "AS t p". The set temperature "SV" can be set by pressing ENTER. The operation time "tim" can be set by pressing it again. Pressing the START/STOP key starts the auto stop operation.	18
4.	Auto Start	This operation is used to specify the automatic start. Pressing the TIMER key displays "AS t r". The set temperature "SV" can be set by pressing the ENTER key. The operation time "tim" can be set by pressing it again. Pressing the START/STOP key starts the auto start operation.	20

NOTE) It is not possible to change modes during operation. If the mode requires change, stop operation.

## Operation Modes and Functions

No.	Name		Description	Page
1.	Overheat prevention	Auto overheat prevention function	This function is automatically activated when temperature exceeds the set temperature by 12°C.	15
		Overheat prevention device	This unit is equipped with an independent temperature measurement circuit, CPU, sensor, and output. The Overheat prevention temperature can be set through the operation panel. The unit stops operation when the device is activated. The unit starts operation again when the POWER switch is pressed again (manual reset).	
2.	Calibration offset function		This calibration offset function is for calibrating the difference occurred between the required in-furnace temperature and control temperature (sensor temperature) of the controller. This unit can be calibrated toward either plus side or minus side of the whole temperature range.	22
3.	Overheat prevention temperature calibration		The temperature of the overheat prevention device is automatically corrected when the temperature of controller is collected.	-
4.	Recovery at power failure		The unit starts operation under the same condition as just before the power failure. Press the START/STOP key to start the unit again.	-
5.	Set value locking		This function locks the established operation status. It can be set and cancelled with the SUBMENU key.	22

## Operational Characters

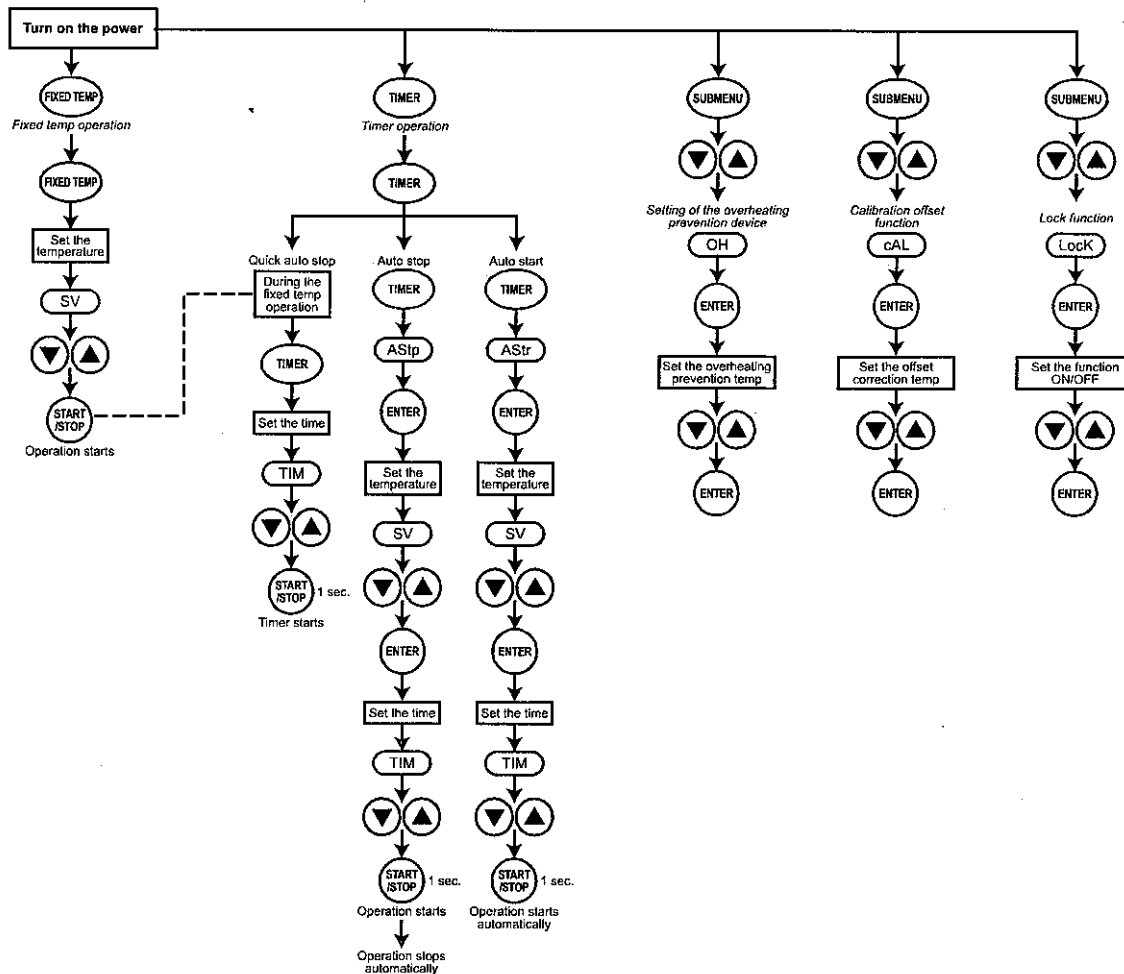



## Overheat Prevention Device

This unit is equipped with an overheat prevention device that consists of an independent temperature measurement circuit, CPU, sensor and output circuit. It shares a power source, display, and key input with the controller, in addition to the automatic overheat prevention function in the controller.

### Set range/function

This unit is equipped with a failsafe function against overheating. One of them is built in the controller and factory set to be automatically activated when the temperature exceeds the set temperature by 12°C.

The other is integrated with the controller, which can be set through the keys on the controller.

**WARNING: The setting range is 0°C to 1300°C. The controller in this unit is also utilized in high temperature furnaces. Exercise extreme care in changing the overheat temperature which is factory set at 312°C.**

In the event that the chamber temperature exceeds the set temperature to reach to that of the overheat prevention device, the circuit is shut off and "Er19" is displayed with visual and audible signals.

If the device is activated, "Er19" continues to be displayed until the power is turned off and on.

### Temperature setting procedure

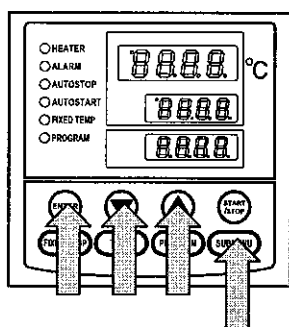

#### 1. Turn the power on (breaker on front panel)

- The default value is displayed for about four seconds after turning on the power and the screen displays the initial setting. The current temperature in furnace, operation mode character and set temperature of the overheat prevention device is also displayed on respective screens.

#### 2. Set the overheat prevention temperature

- Press the SUBMENU key.
- Press the "▼▲" keys several times to select the set character of the overheat prevention temperature "OH".
- Press the ENTER key. The current set temperature is displayed and blinks on the set temperature screen.

**Note:** To prevent improper operation, set the value 12°C or higher than the set temperature.

- Select the value using the "▼▲" keys and press the ENTER key. This completes the setting.

### Notes:



- The standard set temperature of device is "the maximum set temperature of unit plus 12°C" or "setting temperature plus 12°C". If the unit performs improperly, increase it 5°C more.
- The set range of the overheat prevention device is from 0°C to 1300°C. Improper setting of temperature may cause unit to not operate properly, malfunction of device, e.g. it is activated during increase in temperature, or unexpected accidents such as fire. To prevent such matters, set a proper value.
- The temperature is set to 312°C at factory shipment. Do not set the value higher.**
- The overheat prevention device can possibly be activated by accident when its yield temperature is set to approximately room temperature.
- The purpose of the overheat prevention device is to protect the unit from overheating. It does not intend to protect the samples, or to protect them from accidents caused by the use of explosive or inflammable materials.

## Fixed Temperature

### Fixed temperature

#### 1. Turn power on (breaker on front panel)

- ❖ The default value is displayed for about four seconds after turning the power on. The screen then displays the initial setting. The current temperature, operation mode character, and set temperature of the overheat prevention device are displayed on respective screens.

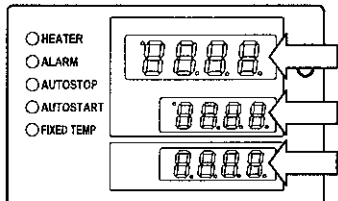

#### Measured temperature screen:

Displays the current temperature in furnace.

#### Set temperature screen:

Displays the operation mode character. (Refer to Page 13)

#### Overheat prevention screen:

Displays the set temperature of overheating prevention device

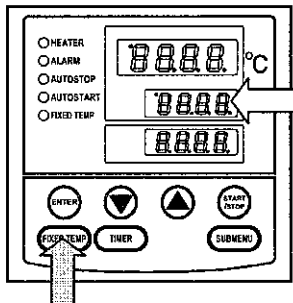

#### 2. Select the operation mode

- Press the FIXED TEMP key to display "FIX", which indicates the fixed temperature operation, on the center display screen.

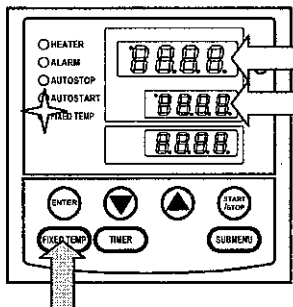

#### 3. Set the temperature

- Press the FIXED TEMP key again.
- The set temperature screen displays the character "SV" which indicates the temperature setting. It also displays and flashes the current set temperature. The FIXED TEMP lamp flashes also.
- Set the temperature by pressing the "▼▲" keys.

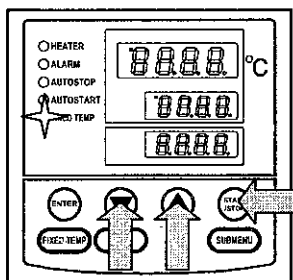

#### 4. Start operation

- Press the START/STOP key for about one second. The unit begins its operation and the flashing FIXED TEMP lamp illuminates.

#### 5. Stop operation

- Press the START/STOP key for about one second. The unit stops operation and the FIXED TEMP lamp turns off. The screen returns to the initial setting screen.

### To correct or check setting...

Press the FIXED TEMP key again to correct or check the setting.

Changing the set temperature during operation is also possible by pressing the FIXED TEMP key.

## Quick Auto Stop

### Quick auto stop procedure

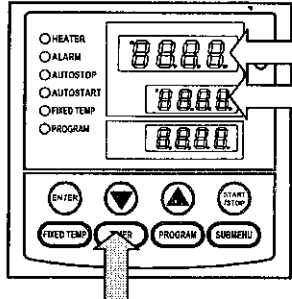

This operation is used to specify the period to automatically stop during operation.

#### 1. Set the stop time in fixed temperature operation

- Check that the FIXED TEMP lamp lights on and that the unit is operating.
- Press the TIMER key.
- The measured temperature screen displays the character "tim", which indicates the timer setting. The set temperature screen displays and flashes the current set time.
- Select the time by pressing the "▼▲" keys.

#### Timer function:

- The maximum set time is "999 hours and 50 minutes".
- The time can be set in increments of a minute under 99 hours and 59 minutes.
- It can be set in increments of ten minutes over 100 hours.
- The "▼▲" keys can quickly change the set time when continuously pressed. Press them consecutively when fine adjustment is needed.

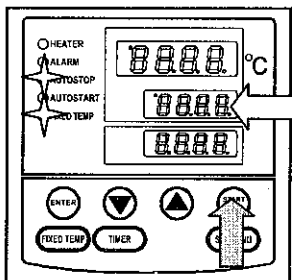

#### 2. Start timer

- Press the START/STOP key for one second after selecting the desired time.
- Timer operation starts with the FIXED TEMP and AUTO STOP lamps on.
- The timer is activated and the START/STOP key is pressed.

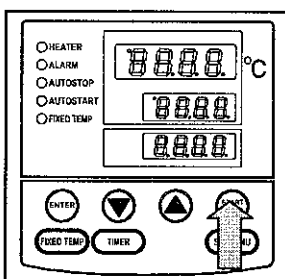

#### 3. Stop/terminate timer

- The operation stops automatically at setting time.
- Buzzer alarms for about five minutes during operation stop.
- The set temperature screen displays the character "End", which indicates termination of operation, with the FIXED TEMP and AUTO STOP lamps on. Press the START/STOP key to terminate the timer operation mode. The screen returns to the initial setting screen.

### To correct or check setting...

Changing the set temperature during operation is possible by pressing the FIXED TEMP key. Press the ENTER key after changing the setting.

Changing the set temperature during operation is available by pressing the FIXED TEMP key. Press the ENTER key after changing the setting.

Press the ▼ key to display the set temperature, operation mode, and residual time on the set temperature screen.

## Auto Stop

### Auto stop operation procedure

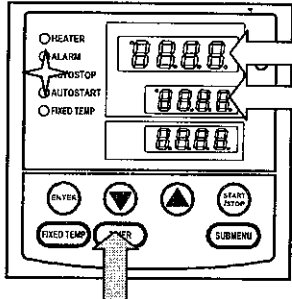

This operation is used to specify the automatic stop time in the fixed temperature operation mode.

#### 1. Set stop time

- ① Press the TIMER key on the initial screen.  
Press the TIMER key again. The set temperature screen displays the character "AstP", which indicates and flashes the auto stop operation.
- ② Press the ENTER key.  
The measured temperature screen displays the character "SV", which indicates the temperature setting. The set temperature screen displays and flashes the current set temperature. The AUTO STOP lamp flashes as well.
- ③ Set the temperature using the "▼▲" keys.
- ④ Press the ENTER key again.  
The measured temperature screen displays the character "tim", which indicates the timer setting. The set temperature screen displays and flashes the current set time.
- ⑤ Set the time using the "▼▲" keys.

#### Timer function:

- The maximum setting time is "999 hours and 50 minutes".
- The time can be set in increments of a minute under 99 hours and 59 minutes.
- It can also be set in increments of ten minutes over 100 hours.
- The "▼▲" keys can quickly change the set time when it is continuously pressed. Press them consecutively when fine adjustment is needed.

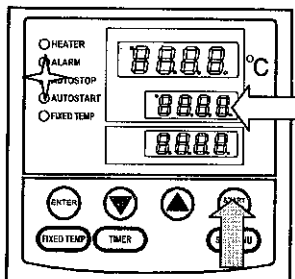

#### 2. Start timer

- Press the START/STOP key for one second after selecting the desired time.
- Timer operation starts with the AUTO STOP lamp on.
- The timer is activated and the interior temperature (measured temperature) reaches to the set temperature.

## Auto Stop

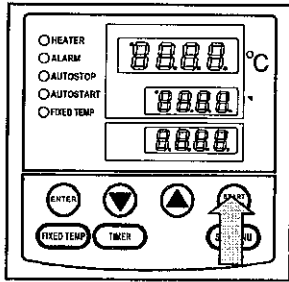

### 3. Stop/terminate timer operation

- The operation stops automatically at setting time.
- Buzzer alarms for about five seconds during operation stop.
- The set temperature displays the character "End", which indicates termination of operation, with the FIXED TEMP and AUTO STOP lamps on. Press the START/STOP key to terminate the timer operation mode. The screen returns to the initial setting screen.

### To correct or check setting...

Changing the set temperature or time during operation is possible by pressing the TIMER key. Use the "▼▲" key to change the set value. Press the ENTER key respectively after changing the setting.

Press the "▼" to display the set temperature, operation mode, and residual time on the set temperature screen.

## Auto Start

### Auto start procedure

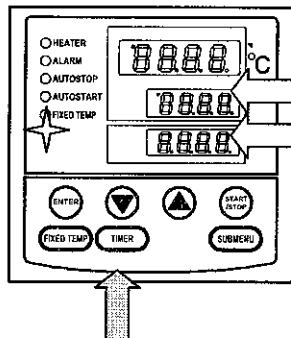

This operation is used to specify the automatic start time after the unit is powered on.

#### 1. Set start time

- ① Press the TIMER key on the initial screen.  
Press the TIMER key again. The set temperature screen displays the character "Astr", which indicates and flashes the auto start operation.
- ② Press the ENTER key.  
The measured temperature screen displays the character "SV", which indicates the temperature setting. The set temperature screen displays and flashes the current set temperature. The AUTO START lamp flashes as well.
- ③ Set the temperature using the "▼▲" keys.
- ④ Press the ENTER key again.  
The measured temperature screen displays the character "tim", which indicates the timer setting. The set temperature screen displays and flashes the current set time.
- ⑤ Set the time using the "▼▲" keys.

#### Timer function:

- The maximum setting time is "999 hours and 50 minutes".
- The time can be set in increments of a minute under 99 hours and 59 minutes.
- It can also be set in increments of ten minutes over 100 hours.
- The "▼▲" keys can quickly change the set time when it is continuously pressed. Press them consecutively when fine adjustment is needed.

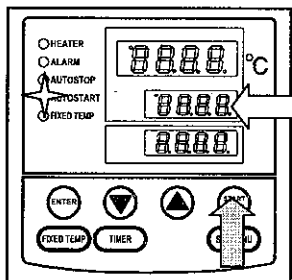

#### 2. Start timer operation

- Press the START/STOP key for one second after deciding the time.
- Timer operation starts with the AUTO START lamp lighting on.

## Auto Start

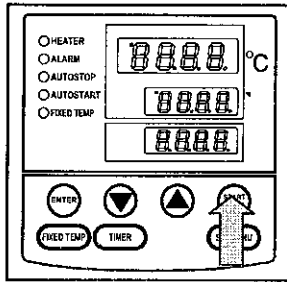

### 3. Stop/terminate timer operation

- The operation automatically starts at setting time.
- Press the START/STOP key for one second to stop or terminate operation. The screen returns to the initial setting screen.

### To correct or check setting...

Changing the set temperature or time during operation is possible by pressing the TIMER key. Use the "▼▲" keys to change the set value. Press the ENTER key after changing the settings. Please note that you will not be able to change parameters after the unit begins operation. In this event, stop the operation by pressing the START/STOP key, and set the value again.

Press the "▼" key to display the set temperature, operation mode, and residual time on the setting temperature screen.

## Other Functions

### Calibration offset

Calibration offset is a function, which corrects the difference between the temperature in unit and that of the controller (sensor temperature). The function parallel corrects the difference to the positive or negative side within the whole temperature range of unit. This function can be set or cancelled through the SUBMENU key.

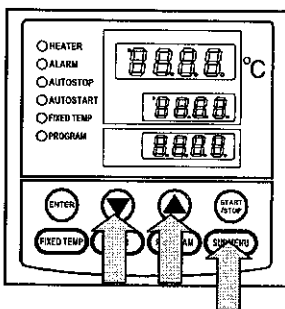
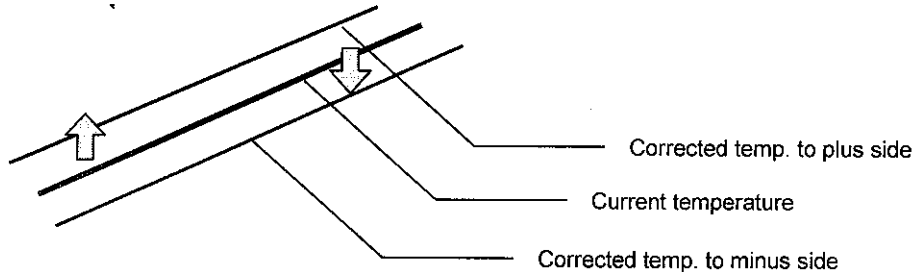

- ① Start operation with the target set temperature. Check the temperature in chamber (temperature of sample) with a thermometer after it is stabilized.
  - ② Check the difference between the set temperature and that in chamber (temperature of sample).
  - ③ Press the SUBMENU key. Select the character "cAL", which indicates the calibration offset, using the "▲▼" keys, and press ENTER.
  - ④ Input the difference using the "▲▼" keys and press ENTER. This completes the setting.
- ❖ The offset setting range is +99°C to the positive side and -99°C to the negative side.
    - When it is set to the negative side, the temperature on the measured temperature screen falls by the set temperature, while the temperature in the chamber rises.
    - When it is set to the positive side, the temperature on the measured temperature screen rises by the set temperature, while the temperature in the chamber falls.
  - ❖ This unit has a two-point calibration function, which performs offset between low-temperature and high-temperature zone. Please consult your sales representative when validating temperature controller.

### Lock function

This function locks the parameters previously set. This function can be set or cancelled through the SUBMENU key.

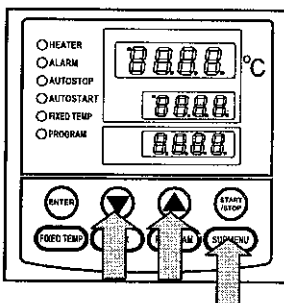

- ① Press the SUBMENU key. Select the character "Lock", which indicates the lock value, using the "▲▼" keys, and press ENTER.
  - ② The set temperature screen displays "oFF". The set value is locked when it is turned "o n" using the "▲" key.
  - ③ Press the SUBMENU key again to cancel the lock. Select the character "Lock", which indicates the lock of the set value, using the "▲▼" keys, and press ENTER. Select "oFF" with the "▼" key and press ENTER to cancel the function.
- ❖ All keys other than the START/STOP and SUBMENU keys are locked when the lock function is on.





### **WARNING!**

 If smoke or strange odors come out of this unit, turn the power, circuit breaker, and main power off immediately. Contact Yamato or your service representative for inspection. Not following these procedures may result in fire or electrical shock. Do not perform any repair work without consulting Yamato.

 Never use explosive or flammable substances or substances that include explosive or flammable ingredients. Doing so can result in explosion or fire. (Refer to page 33 "List of Dangerous Substances".)

### **CAUTION!**

 During a thunderstorm, turn the power, circuit breaker and main power off immediately. Not following this procedure may result in fire or electrical shock.

 • Keep door closed during operation -- The heater will not function properly if the door is left opened during operation.  
• Do not leave door ajar after operation. The heat from chamber may damage control panel or control devices.

 Do not use corrosive samples. Strong acids or samples similar may corrode even type 304 Stainless steel. The door gaskets made of silicone may also corrode by solvent such as alkaline, oil, halogen etc.

 Operational temperature range of this unit is Ambient +5°C to 300°C. Never set the temperature beyond this range.

## Handling Precautions

- ⊘ The maximum shelf load is approximately 33 lbs./15 kg per shelf. When loading samples, place conservatively in chamber with adequate space between samples. Overloading may cause improper temperature control. For best temperature results, allow 30% or more space between samples.

- ⊘ Do not place samples directly on bottom panel of unit. Not following these instructions can cause serious internal temperature problems. Be sure to install the shelves provided.



**Samples  
on bottom chamber**

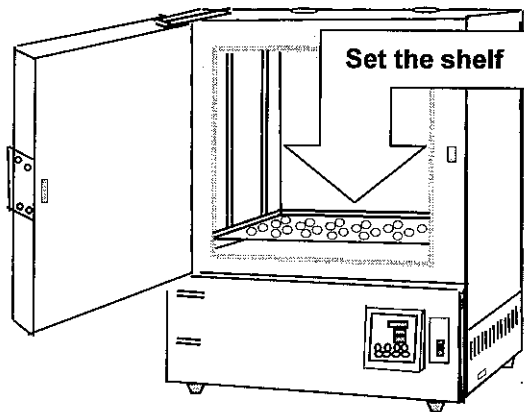

- ⚠ When the power is restored after a power failure, the device automatically resumes operation from the state as just before the power failure. Be cautious in this situation. It is not recommended that you leave the unit unattended. As a safety precaution, we recommend that you turn off the power switch in the event of a power failure.

### Double stacking

- ⚠ Do not stack units directly on top of each other.
- ⊘ An optional metal stacking kit is available through Yamato Scientific. Please contact Yamato for further details.

## Daily Inspection and Maintenance

As safety precaution, please perform the following daily inspections and maintenance services.

### **WARNING!**

- Disconnect the power cord from the power source when performing an inspection or maintenance.
- Perform daily inspections and maintenances after returning the temperature of this unit to room temperature.
- Do not disassemble this unit.

### **CAUTION!**

- Use a well-drained soft cloth to wipe dirt on this unit. Do not use benzene, thinner or cleanser for wiping. Do not scrub this unit. Deformation, deterioration or color change may result.

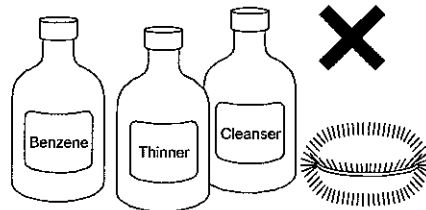

Please contact Yamato Scientific with any questions you may have.  
1-800-2-YAMATO (1-800-292-6286)

## **CAUTION!**

### Not in use

- Turn off the power and disconnect the power cord.

## **WARNING!**

### Disposing

- Keep out of reach of children.
- Remove the door and driving parts.

### ***Environmental protection should be considered***

We request you to disassemble this unit as much as possible to recycle reusable parts.

The feature components of this unit and materials used are listed below.

Component	Material
<b>Exterior Parts</b>	
Outer panels	Steel plate melamine resin coating
Chamber	Stainless steel Type 304 (18-8)
Heat insulation material	Rock wool
Shelves	PET resin film
<b>Electrical Parts</b>	
Heater	Iron- chrome heater
Circuit boards	Board, Condenser, Transformer and other
Power cord, Wiring	Synthetic rubber or resin coated wiring materials

## Safety Devices and Error Codes

This unit has an automatic diagnosis function built in the controller along with safety devices independent of the controller. The table below explains cause and solution methods when the safety device operates.

### Error Codes:

If an abnormal condition should occur, an error code appears and you are visually and audibly alarmed. Record the error code and turn the power off immediately.

Safety Device	Notify	Cause/Solution
Sensor trouble detection	"ALARM" lamp on, "Er.01" appears	<ul style="list-style-type: none"> <li>Damaged or disconnected temperature sensor.</li> <li>Contact your service representative</li> </ul>
SSR short-circuit detection	"ALARM" lamp on, "Er.02" appears	<ul style="list-style-type: none"> <li>Short-circuit in triac.</li> <li>Contact your service representative.</li> </ul>
Heater disconnection detection	"ALARM" lamp on, "Er.03" appears	<ul style="list-style-type: none"> <li>Disconnected heater.</li> <li>Contact your service representative.</li> </ul>
Memory error	"ALARM" lamp on, "Er.15" appears	<ul style="list-style-type: none"> <li>Failure in internal memory.</li> <li>Contact your service representative.</li> </ul>
Internal communication error	"ALARM" lamp on, "Er.17" appears	<ul style="list-style-type: none"> <li>Failure in internal communication or temperature inputting circuit.</li> <li>Contact your service representative.</li> </ul>
Overheat	"ALARM" lamp on, "Er.19" appears	<ul style="list-style-type: none"> <li>Overheat prevention device is in operation.</li> <li>Reset the power supply, and then adjust the set temperature of the overheat protection device.</li> <li>Contact your service representative.</li> </ul>
Measured temperature error	"ALARM" lamp lights on, "-----" appears	<ul style="list-style-type: none"> <li>Measured value out of display range.</li> <li>Contact your service representative.</li> </ul>

When Technical assistance is required, please contact Yamato Scientific America and have the following information available.

Condition	Probable Cause(s)
The device does not start when turning on the power switch.	<ul style="list-style-type: none"><li>• Power plug is not connected to the receptacle correctly.</li><li>• Power failure.</li></ul>
Temperature fluctuates during the operation.	<ul style="list-style-type: none"><li>• Overload of samples.</li><li>• Air conditioner directly blowing on unit.</li><li>• Fluctuation of ambient temperature.</li><li>• Samples are too moist.</li><li>• Power supply voltage is lower than proper value.</li></ul>

Should you experience any of the errors listed above, be sure to turn the power switch and primary power source off immediately and contact Yamato.  
1-800-2-YAMATO (1-800-292-6286)

### Request for Repair

Should you experience any difficulties, stop operation, turn power switch off, unplug the power plug, and contact Yamato Scientific America's Service Department.

**< Please have the following information readily available >**

- ◆ Product Model Number
  - ◆ Serial Number
  - ◆ Date of Purchase
  - ◆ Detailed Troubles
- } Refer to the serial number plate attached to unit.

### Spare Parts for Repair

Yamato Scientific guarantees availability of spare parts for 5 years after units are discontinued.

## Specifications

	DX300	DX400	DX600
Temperature control range	(Ambient temp.: 23°C, No load)		
Temperature accuracy	Ambient +5°C to 300°C		Ambient +5°C to 280°C
Temperature uniformity <sup>1</sup>	±1.9°C @ 100 °C / ±3.0°C @ 200 °C (Set temp.: 260°C, Exhaust opening: one-third opened)		
Temperature control range	±210°C (Set temp.: 280 or 300°C, Exhaust opening: 1/3 opened)		
Temperature rise time	Approx. 45min. (Room temp. to 300°C)	Approx. 60min. (Room temp. to 300°C)	Approx. 80min. (Room temp. to 280°C)
Heater	Iron-chrome heater		
	0.9kw	1.5kw	
Controller	HITEC® VS3 type		
Temperature control system	PID control for heater output by microprocessor		
Setting system	Digital		
Operation mode	Fixed temperature, Quick auto stop, Auto stop, Auto start operation		
Sensor	K-thermocouple		
Additional functions	Lock function, Auto recovery after power failure, Calibration offset		
Self-diagnostic functions	Failure of Sensor, heater, SSR, memory, internal communication, temperature input circuit, automatic overheat prevention device, independent overheat prevention device, measured temperature		
Safety device	Earth leakage breaker, Overheat prevention device		
External dimensions (W × D × H)	15.7 x 17.3 x 24.3, inch (400 × 440 × 617 mm)	21.7 x 21.2 x 28.4, inch (550 × 540 × 722 mm)	27.6 x 25.2 x 32.4, inch (700 × 640 × 822 mm)
Internal dimensions (W × D × H)	11.8 x 12.2 x 11.8, inch (300 × 310 × 300 mm)	17.7 x 16.1 x 15.7, inch (450 × 410 × 400 mm)	23.6 x 20.1 x 19.7, inch (600 × 510 × 500 mm)
Capacity	1.0 cu. ft. (28ℓ)	2.6 cu. ft. (74ℓ)	5.4 cu. ft. (153ℓ)
Door	Single door, silicon packing		
Power supply (50/60Hz)	115V AC		
	8A	13.5A	13.5A
Weight	Approx. 52.9 lbs. (24Kg)	Approx. 83.8 lbs. (38Kg)	Approx. 123.5 lbs. (56Kg)
Accessories	Shelf × 2 (maximum load: 33 lbs. (15kg) /per shelf), Instruction manual		

<sup>1</sup> Based on average performance of ASTM E145

❖ The performances under the power supply condition of AC 115V are shown here.

❖ The usable ambient temperature of the unit is from 5°C to 35°C.



## DX300/400/600

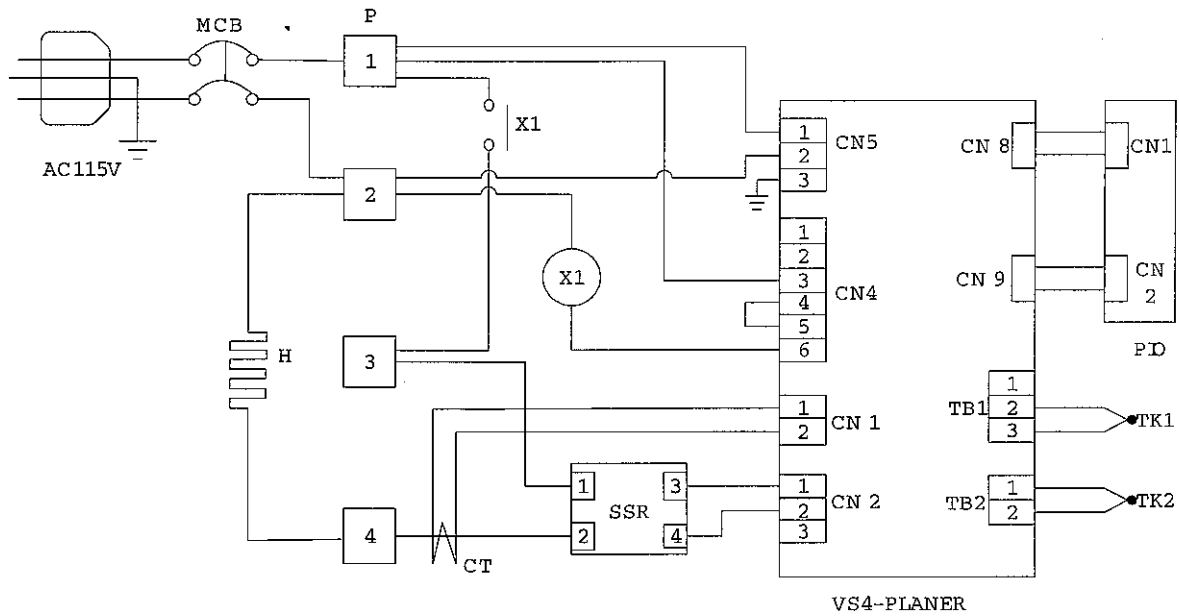

Symbol	Part name	Symbol	Part name
MCB	Circuit breaker	VS4-PLANAR	Control board
P	Terminal block	PIO	Display circuit board
H	Heater	TK1	Sensor for control
X1	Main relay	TK2	Sensor for overheat prevention
SSR	Breakerless relay	CT	Current transformer

## Replacement Parts Table

### Common for DX300/400/600

Part Name		Specification	Code No.	Yamato P/N
Control and Overheat Sensor		LCK-M 1 -2000-Y K single	1160030049	DKN-100-N
CPU (Planar) board		VS3	1020000047	DKN-0058-N
Display board		VS3	1020000051	DKN-110-N
Display/keypad interface ribbon cable		50mm	1130000009	DKN-122-N
Main power relay		AHE1254 115V/120V	2050000019	DKN-103-N
Solid State Relay (SSR)		TRS5225	2160000035	DKN-A004-N
Power cord assembly	DX300	1.25sq 3p plug	DN004	DX-CORD-N
	DX400/600	2.0sq 3p plug	DN003	DKN-CORD-N
Main Circuit breaker	DX300	FB32B-15 15A	2060000038	DKN-400-002-N
	DX400/600	FB32B-20 20A	2060000039	DKN-600-002-N
Current Transformer (CT)		CTL-6-S-H	2170010005	DKN-106-N
Heater	DX300			DX-300-002-N
	DX400			DX-400-002-N
	DX600			DX-600-002-N
Terminal Connector		4 PIN		DKN-115-N
Door handle assembly		Type 304 Stainless Steel		DX-013-N
Door latch		Type 304 Stainless Steel		DX-300-012-N
Door gasket	DX300	Silicone		DX-300-004-N
	DX400	Silicone		DX-400-004-N
	DX600	Silicone		DX-600-004-N
Rubber Feet				OV-FEET-N
Keypad panel sheet		VS3	9300000237	VS3-2283-N
Shelf	DX300	Type 304 Stainless Steel		DX-300-903-N
	DX400	Type 304 Stainless Steel		DX-400-903-N
	DX600	Type 304 Stainless Steel		DX-600-903-N
Shelf brackets		Type 304 Stainless Steel		DX-300-009-N

## List of Dangerous Substances



Never use explosive or flammable substances, or substances that include explosive or flammable ingredients.

## EXPLOSIVE

EXPLOSIVE:	Ethylene glycol dinitrate (nitro glycol), Glycerin trinitrate (nitroglycerine), Cellulose nitrate (nitrocellulose), and other explosive nitrate esters
	Trinitrobenzene, Trinitrotoluene, Trinitrophenol (picric acid), and other explosive nitro compounds
	Acetyl hidroperoxide (peracetic acid), Methyl ethyl ketone peroxide, Benzyl peroxide, and other organic peroxides

## FLAMMABLE

IGNITING:	Lithium (metal), Potassium (metal), Sodium (metal), Yellow phosphorus, Phosphorus sulfide, Red phosphorus, Celluloid compounds, Calcium carbide, Lime phosphate, Magnesium (powder), Aluminum (powder), Powder of metals other than magnesium and aluminum, Sodium hydrosulfite
OXIDIZING:	Potassium chlorate, Sodium chlorate, Ammonium chlorate, and other chlorate
	Potassium perchlorate, Sodium perchlorate, Ammonium perchlorate, and other perchlorate
	Potassium peroxide, Sodium peroxide, Barium peroxide, and other inorganic peroxide
	Potassium nitrate, Sodium nitrate, Ammonium nitrate, and other nitrate
	Sodium chlorite and other chlorites
Calcium hypochlorite and other hypochlorites	
INFLAMMABLE LIQUID:	Ethyl ether, Gasoline, Acetaldehyde, Propylene chloride, Carbon disulfide, and other flammable substances having a flash point of lower than -30°C
	Normal hexane, ethylene oxide, acetone, benzene, methyl ethyl ketone, and other flammable substances having a flash point of -30°C or higher but lower than 0°C
	Methanol, Ethanol, Xylene, Pentyl acetate (amyl acetate), and other flammable substances having a flash point of 0°C or higher but lower than 30°C
	Kerosene, Light oil (gas oil), Oil of turpentine, Isopentyl alcohol (isoamyl alcohol), Acetic acid, and other flammable substances having a flash point of 30°C or higher but lower than 65°C
FLAMMABLE GAS:	Hydrogen, Acetylene, Ethylene, Methane, Propane, Butane, and other flammable substances which assume a gaseous state at 15°C and 1 atm

(Source: Appendix Table 1 of Article 6 of the Industrial Safety and Health Order in Japan)

## **Responsibility**

Please follow the instructions in this document when using this unit. Yamato Scientific has no responsibility for the accidents or breakdown of device if it is used with a failure to comply. Never conduct what this document forbids. Unexpected accidents or breakdown may result in.

## **Note**

- ◆ The contents of this document may be changed in future without notice.
- ◆ Any books with missing pages or disorderly binding may be replaced.

Instruction Manual for  
**GRAVITY CONVECTION OVENS**  
**Model DX300/400/600**  
First Edition Feb. 13, 2006

---

**Yamato Scientific America, Inc.**  
925 Santa Clara, Walsh Avenue,  
TCA 95050, U.S.A  
<http://www.yamato-usa.com>